

Data sheet

Differential pressure switch

MP 54, MP 55 and MP 55A



MP 54 and MP 55 oil differential pressure switches are used as safety switches to protect refrigeration compressors against low lubricating oil pressure.

If the oil pressure fails, the oil differential pressure switch stops the compressor after a certain time period.

MP 54 and MP 55 are used in refrigerating systems using HCFC and non-flammable HFC refrigerants.

MP 55A is used in refrigerating systems with R717. MP 55A can also be used in systems with HCFC and non-flammable HFC refrigerants.

MP 54 has a fixed differential pressure setting. It also incorporates a thermal time relay with a fixed release time setting.

MP 55 and MP 55A have adjustable differential pressure and are available both with and without thermal time relay.

Features

- Wide regulating range
- Can be used for deep freeze, refrigeration and air conditioning plant
- Can be used for HCFC and non-flammable HFC refrigerants
- Electrical connection at the front of the unit
- Suitable for both alternating and direct current (AC and DC)
- Screwed cable entry for cables from 6 – 14 mm diameter
- Small contact differential

Approvals

CE mark according to LVD 2006/95/EC
EN 60947-1, EN 60947-4-1, EN 60947-5-1

China Compulsory Certificate, CCC
Versions having UL and CSA approvals can be supplied to special order

Ship approvals

Germanischer Lloyd, GL
Registro Italiano Navale, RINA (MP55)

Materials in contact with the medium

Unit type	Material
MP 54 MP 55	Stainless steel 19/11, no. 1.4306 to EN 10088 Cold forming steel, no. 1.0338, EN 10139 Free cutting steel, no. 1.0718, EN 10277
MP 55A	Stainless steel 19/11, no. 1.4306 to EN 10088 Cold forming steel, no. 1.0338, EN 10139 Free cutting steel, no. 1.0401, EN 10277-2

Technical data

Control voltage	230 V or 115 V AC or DC	
Permissible voltage variation	-15 – 10%	
Max. working pressure	PS/MWP = 17 bar	
Max. test pressure	P _e = 22 bar	
Ambient temperature The time relay is temperature-compensated in the range	-40 – 60 °C	
Screwed cable entry	P _g 13.5	
Cable diameter	6 – 14 mm	
Max. bellows temperature	100 °C	
Switch differential max. Δp [bar]	0.2	
Enclosure	IP20 to EN 60529 / IEC 60529	
Contact loads	MP with time relay (contacts M-S)	AC15 = 2 A, 250 V DC13 = 0.2 A, 250 V
	MP without time relay	AC15 = 0.1 A, 250 V DC13 = 12 W, 125 V
Wire dimensions	solid / stranded	0.2 – 1.5 mm ²
	flexible, without ferrules	0.2 – 1.5 mm ²
	flexible, with ferrules	0.2 – 1 mm ²
Tightening torque	max. 1.2 Nm	
Rated impulse voltage	4 kV	
Pollution degree	3	
Short circuit protection, fuse	2 A	
Insulation	250 V	

Terminology
Differential range

The pressure difference between LP and OIL connections within which the switch can be set to operate.

Scale reading

The differential between the oil pump pressure and the pressure in the crankcase that exists at the moment the contact system cuts in current to the time relay on falling oil pressure.

Operating range

The pressure range on the LP connection within which the switch can operate.

Contact differential

The pressure rise above the set differential pressure (scale reading) necessary to cut off current to the time relay.

Release time

The period for which the differential pressure switch allows the compressor to run with too low an oil pressure during start-up and operation.

Ordering

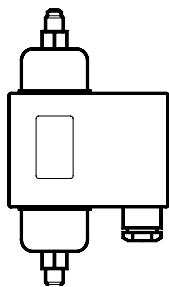

For HCFC and non-flammable HFC refrigerants

Type	Differential Δp [bar]	Operation range, LP side [bar]	Relay release time [s]	Code no.		
				Connection		
				1/4 in Flare	1 m cap.tube 1/4 in ODF solder	M12 x 1.5 with 6 mm cutting ring
MP 54	0.65	-1 - 12	0 ²⁾	060B029766	-	-
	0.65	-1 - 12	45	060B016666	-	-
	0.9	-1 - 12	60	060B016766	-	-
	0.65	-1 - 12	90	060B016866	-	-
	0.65	-1 - 12	120	060B016966	-	-
MP 55	0.3 - 4.5	-1 - 12	45	060B017066	060B013366	-
	0.3 - 4.5	-1 - 12	60	060B017166	-	-
	0.3 - 4.5	-1 - 12	60	060B017866 ¹⁾	-	-
	0.3 - 4.5	-1 - 12	90	060B017266	-	-
	0.3 - 4.5	-1 - 12	120	060B017366	-	-
	0.3 - 4.5	-1 - 12	0 ²⁾	060B029966	-	-

For R717, HCFC and non-flammable HFC refrigerants

Type	Differential Δp [bar]	Operation range, LP side [bar]	Relay release time [s]	Code no.	
				Connection	
				G 3/8 A supplied with $\varnothing 6.5 / \varnothing 10$ mm weld nipple	M12 x 1.5 with 6 mm cutting ring
MP 55A	0.3 - 4.5	-1 - 12	45	060B017466	060B018266
	0.3 - 4.5	-1 - 12	60	060B017566	060B018366
	0.3 - 4.5	-1 - 12	60	060B017966 ¹⁾	-
	0.3 - 4.5	-1 - 12	90	060B017666	060B018466
	0.3 - 4.5	-1 - 12	120	060B017766	060B018566
	0.3 - 4.5	-1 - 12	0 ²⁾	060B029866 ²⁾	060B029666

¹⁾ With glow lamp that remains on during normal operation.
Note: If the operational light goes out, the compressor should not run longer than the release time.

²⁾ MP without time relay. Versions without time relay are for applications where an external time relay is required – perhaps with a different release time than the one specified.

Design

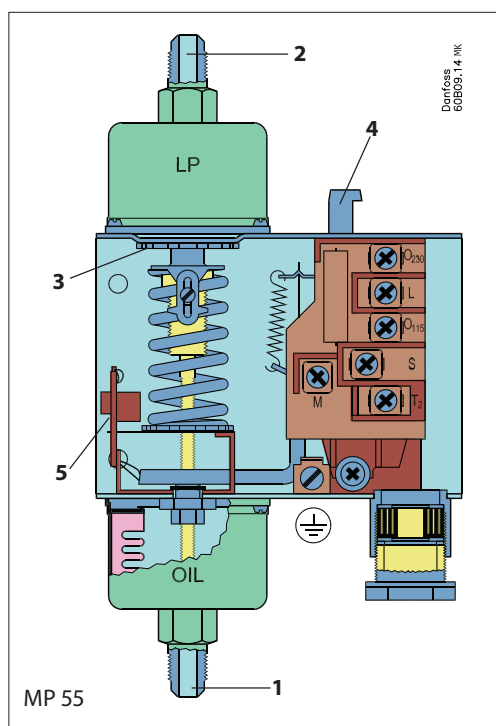

1. Connection to pressure side of lubrication system, OIL
2. Connection to suction side of refrigeration plant, LP
3. Setting disk (MP 55 and MP 55A)
4. Reset button
5. Test device

The operation of the pressure switch relies only on the differential pressure, i.e. the difference in pressure between the two counteracting bellows, whereas it is independent of the absolute pressure acting on both bellows. The MP 55 and 55A can be set for different differential pressures by the setting disc (3). The set differential pressure can be read from the internal scale. The MP 54 has a fixed differential and has no pressure setting disc. The factory-set differential pressure is stamped on the front plate of the switch.

Function

If there is no oil pressure on starting, or if the oil pressure falls below the set pressure during operation, the compressor will stop after the release time has elapsed.

The electrical circuit is divided into two completely separate circuits: a safety circuit and an operational circuit.

The timer (e) in the safety circuit is activated when the effective lubricating oil pressure, the *oil differential pressure* (the difference between the oil pump pressure and suction pressure), is lower than the set value.

The timer is deactivated when the oil differential pressure is more than the set value plus the contact differential.

Electrical diagram

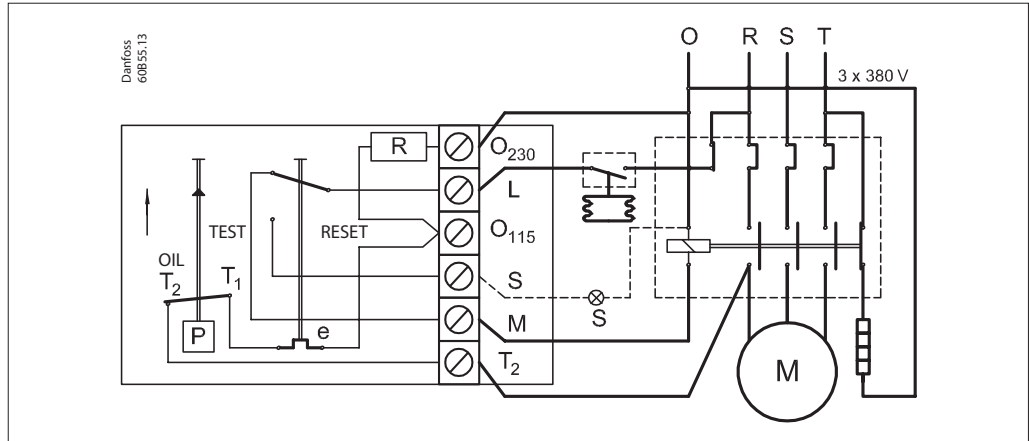

The two diagrams below explain the terms "oil differential pressure" and "contact differential". Both have to be considered when using oil differential pressure switches.

The first diagram shows the function of the differential switch during start; the second shows the function of the switch during operation.

During start

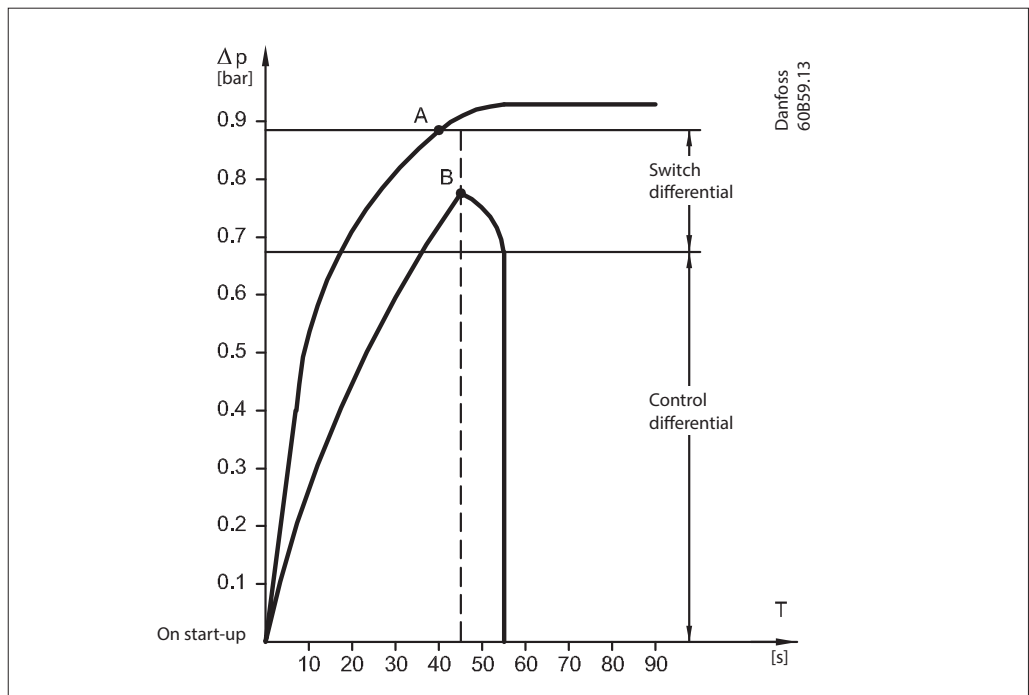

Pos. A: Normal start-up. The lubricating oil pressure is built up during start to the set/fixed differential plus the contact differential, before the timer cuts out (in this example, after 45 seconds). At point A contacts T1-T2 open and timer (e) is stopped, i.e. normal lubricating oil conditions for the compressor have been established.

Pos. B: The lubricating oil pressure does not reach the set/fixed differential plus the contact differential before the timer period elapses. At point B the timer cuts out operational circuit L-M and the compressor stops. If a signal source is connected to terminal S, it will be activated. Restart can only be performed after about 2 minutes by activation of the reset button, provided the cause of the fault has been determined.

Function
(continued)

During operation

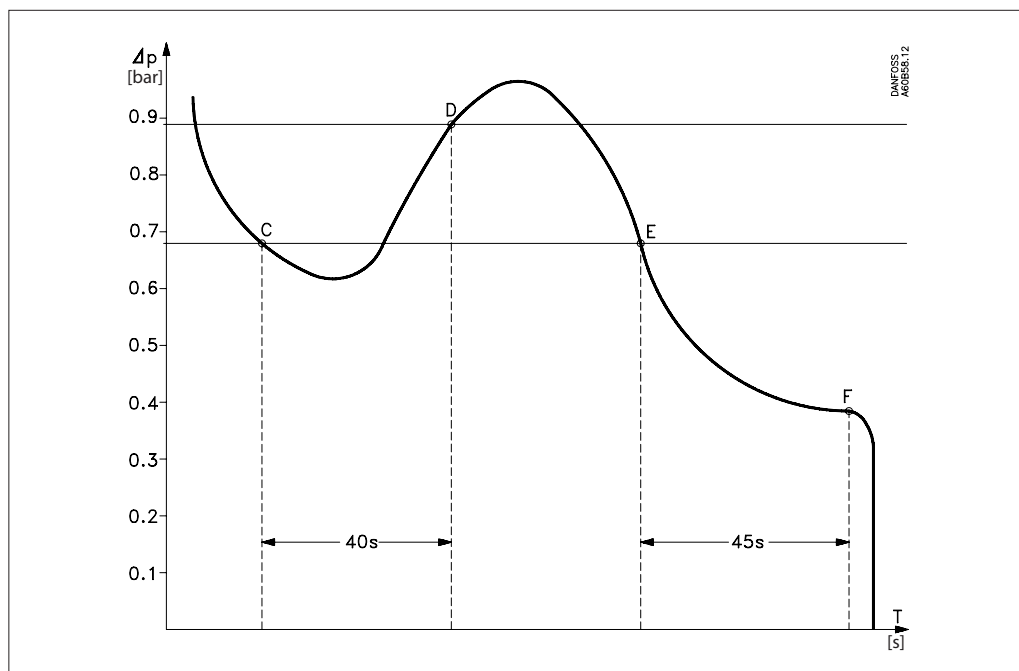

Pos. C: The lubricating oil pressure falls during operation to a value lower than the set/fixed differential. At point C, safety circuit T1-T2 cuts in and the timer is activated.

Pos. D: The lubricating oil pressure reaches the set/fixed differential plus the contact differential before the timer period elapses. At point D, safety circuit T1-T2 cuts out and the timer is stopped, i.e. normal lubricating oil conditions for the compressor have been established.

Pos. E: The lubricating oil pressure falls to a value lower than the set/fixed differential during operation. At point E, safety circuit T1-T2 cuts in and the timer is activated.

Pos. F: The lubricating oil pressure remains lower than the set/fixed differential. At point F the timer cuts out operational circuit L-M and the compressor stops. If a signal source is connected to terminal S, it will be activated. Restart can only be performed after about 2 minutes by activation of the reset button, provided the cause of the fault has been determined.

After start-up

It is important that a function check should be made to ensure that the differential pressure control is operating as it should.

This check can be made by pressing the test device (inside the unit on the left hand side).

When the test device is pressed down and held in this position, the compressor motor should stop after the release time determined by the time relay has elapsed.

**Dimensions [mm]
and weight [kg]**

MP 54, MP 55, MP 55A

