

Date 26/11/2015
 For the attention of:
 Reference
 Operator



COMMERCIAL UNIT COOLER:CUBIC
Type: F27HC 19 N 6
N. units: 1

Refriger (u) 2015 Ver. 2.1.4.293 - PRICE LIST 1/2015

| | | | |
|--|---|----------------------|---|
| Inlet air temp. (room) | [°C] | | 2,0 |
| Room relative humidity | [%] | | 85 |
| Refrigerant | | | R448A |
| Altitude | [m] | | 0 |
| Residual static pressure | [Pa] | | 0 |
| DT1 needed for unit cooler | [K] | | 10,0 |
| Connection | | 230V-1PH-50Hz | |
| Actual capacity | [W] | | 1.850 |
| Air flow | [m3/h] | | 950,0 |
| Air throw | [m] | | 11 |
| Outlet air temperature | [°C] | | -2,3 |
| Evaporating temp | [°C] | | -8,0 |
| DT superheating | [K] | | 5,0 |
| Temp. before expansion valve | [°C] | | 30,0 |
| DT1 | [K] | | 10,00 |
| DTmlg | [K] | | 7,65 |
| Fluid pressure drop | [K] | | 2,5 |
| RC factor (Sensible capacity/Total capacity) | [%] | | 71,6 |
| Energy efficiency class | | | E (2014 thresholds) |
| Fan motor consumpt. | [W] | | 85 |
| Power draw | [A] | | 0,6 |
| Max fan absorbed current | [A] | | 0,61 |
| Fan speed | [1/min] | | 1450 |
| Sound pressure level (5m) | [dB(A)] | | 37 |
| Sound Power Level | [dB(A)] | | 62 |
| COMPRESSOR CAPACITY | [W] | | 1.850 |
| Required condenser capacity | [W] | | 2.620 (-8,0 / 40,0 °C) (Type Semi - hermetic) |
| N° Fans | [mm] | 1 x 275 | Weight [kg] 11 |
| Poles | [n] | 4 | Connections in [n] x [mm] 1 x 9 |
| Fin spacing | [mm] | 6 | Connections out [n] x [mm] 1 x 10 |
| Internal volume | [dm3] | 0,80 | Drain tray connection ["] 3/4 |
| Surface | [m2] | 5,6 | Overall dimensions [mm] 678 x 330 x 415 |
| Max Working pressure | [bar] | 24,0 | |
| Casing material | Powder coated galvanized steel RAL 9003 | | Fin material Al |
| Header material | Cu | | Tube material Cu |

* Refer to LU-VE S.p.A catalogues for details, presentation of data and standards. Noise level in 5m free field. The current may increase according to temperature frost quantity, external static pressure. The weight and dimensions are not valid for all possible configurations. All fans are ErP 2015-compliant (Directive 2009/125/EC Energy-related products). LU-VE S.p.A. reserves the right to modify and correct at any time, with or without notice, the specifications and prices listed in the Refriger software.

LUVE S.p.A Headquarters Uboldo ITALY via caduti della Liberazione, 53

Tel +39 02 967161 Fax +39 02 96780560 mail sales@luvegroup.com web www.luve.it

| | | | | | | |
|-----------|------------|---------|-----------|--------|-----------|-----------|
| Australia | Costa Rica | France | Hong Kong | Poland | Singapore | UAE |
| Austria | China | Germany | India | Russia | Spain | UK & Eire |

For contact details see www.luve.it

F27HC

1450 ÷ 9400 W

18 MODELS

72 VERSIONS

Unit coolers for cold rooms.

The dimensional and functional characteristics that distinguish the super compact - super efficient cooler range are:

- Super efficient heat exchanger
- Reduced dehumidification
- Reduced frost formation
- Increased air throw
- Greatly reduced internal volume
- Low noise levels
- Low energy consumption
- Very compact overall dimensions.

New features of unit coolers F27HC

- New strong casing manufactured in galvanised steel, powder coated.
- New motors wiring with electrical box IP 55.
- New mounting brackets to eliminate the empty space between the unit cooler and the room ceiling.

BENEFIT

Unit coolers range **F27JC** with new patented **JET-O-MATIC®** distributor LU-VE Contardo.

JET-O-MATIC®

Maximum unit cooler capacity at every condition of heat load, room temperature, temperature difference and refrigerant type, specially with the new refrigerants characterized by a mixture with high gas/liquid ratio after the expansion valve.

HITECH

Standard unit coolers range **F27HC**.

New Turbocoil 2 Heat Exchanger

Our super efficient Turbocoil 2 heat exchanger has a high ratio of capacity/cost, that has been achieved by the following:

Tubes

New small diameter inner grooved helical, high efficiency copper tubes specially developed for the new refrigerants.

Turbofin 2

New aluminium high efficiency fins with special turbulence, reducing dehumidification and frost formation.

Fin Spacing

To satisfy all refrigeration requirements in High, Medium and Low temperature application and in different humidity conditions three new ranges of unit coolers are available

- Range **4** = Fin spacing 4,5 mm
- Range **6** = Fin spacing 6,0 mm
- Range **7** = Fin spacing 7,0 mm

Distributor and Refrigerant Circuit

Distributors and refrigerant circuits optimised to ensure maximum efficiency of the heat exchanger in various applications of the unit cooler.

BENEFIT range (J): **JET-O-MATIC®** distributor.

HITECH range (H): Venturi distributor.

Suction pressure gauge connection

This allows for the checking of suction pressure and correct performance of the unit cooler.

Fan Motor Assembly

All models use a new type of high efficiency low consumption fan motor assembly, incorporating internal thermal protection. The fans have been statically and dynamically balanced, fan motor assembly are wired to the unit's electrical box.

275 mm diameter motor assembly

- Voltage 1ph 230V 50/60Hz
- Insulation class B
- Protection IP 42.

Electrical box

- Protection IP 55.

Fan Shroud and Grille

The new fan shroud and air directional grills are designed to obtain a homogeneous airflow along with a long air throw. The grill conforms to the strictest of safety norms.

Electric Defrost

The stainless steel electric heater element permits a quick and efficient defrost of the coil. The heater elements are connected to the unit's electrical box. For special and particularly aggravated conditions of applications a heavy-duty electric defrost for both the coil and shroud is available

.Electrical box

Protection IP 54.

Casing

Specially designed Steel galvanised casing with **Epoxy-Polyester** powder coating corrosion resistant. The new designed casing is carefully constructed and painted to blend with materials normally used in cold rooms.

Maintenance and Cleaning

Access to all internal parts can be achieved with one tool; the grill, side panels and drip tray are easily detached giving access to fan motor assemblies, electric heater elements, and TEV.

The units are EUROVENT certified

Design standard

The products are provided for incorporation in machines as defined in the EC Machine Directive **89/392/EEC** and subsequent modifications according to the following safety standard references:

- **EN 60/335-1 (CEI 61-50)** Safety of household and similar electrical appliances. General requirements.
- **CEI-EN 60/335-2-40** Safety of household and similar electrical appliances - Part 2: Particular requirements for electrical heat pumps, air conditioners and dehumidifiers.
- Machine Directive **89/336 EEC** and subsequent modifications. Electromagnetic compatibility.
- Directive **73/23 EEC** Low tension.
- **EN 294** Fan guards.

Quality Assurance

LU-VE is a certificated company to UNI EN ISO9001:2000, which is the most important Quality Assurance qualification, covering Development, Testing, Production method and Inspection procedures.

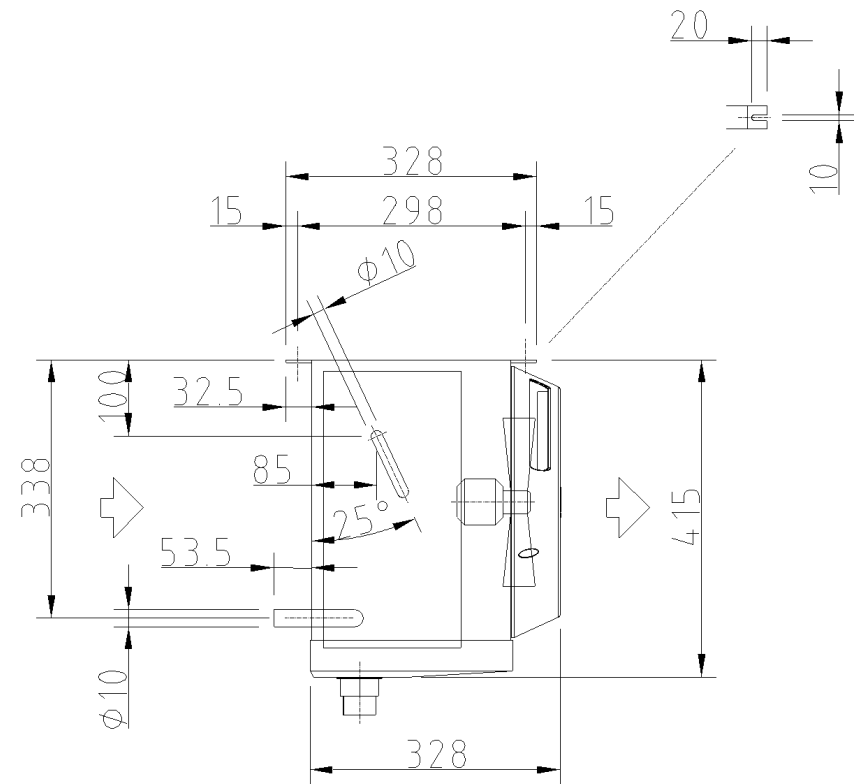
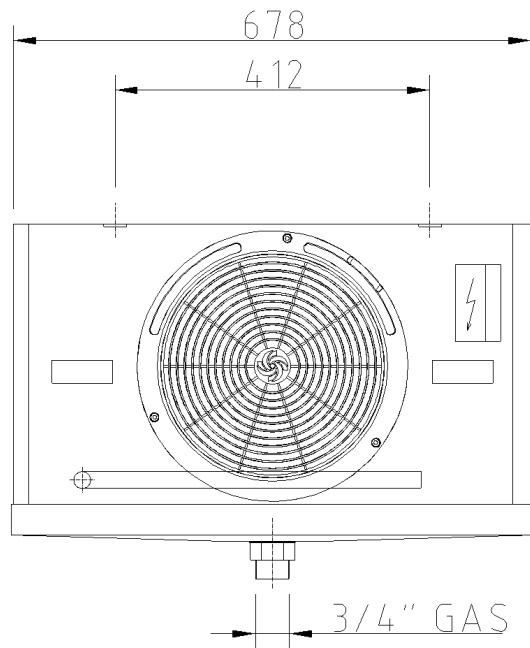

| | | |
|-------|----------|--------------------|
| Date | 2-3-2008 | Type: F27HC 19 N 6 |
| Scale | 1:1 | Code: 10054732 |
| | | |

Drawing refers to a machine in standard configuration, accessories not shown.