



Compressor
Voltage Code : FZ

CAJ2432X

Low Temp. Commercial (BP)

220 - 240V 1~ 50 Hz

R452A / R404A / R449A

AJ2422X-FZ3B

Conditions	Frequency	Nominal Cooling Capacity		Sound Power ISO3745 / ISO 3743-1
		Watts	BTU/h	
EN12900 / R452A	50 Hz	350	1195	58 dBA
EN12900 / R404A	50 Hz	391	1332	58 dBA
EN12900 / R449A	50 Hz	296	1010	58 dBA

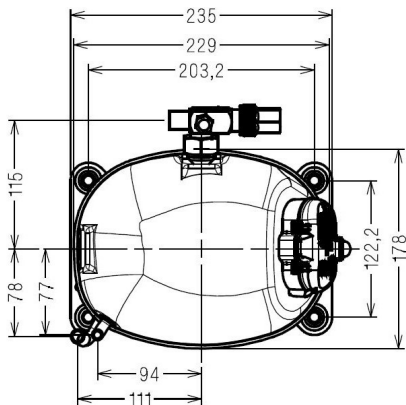
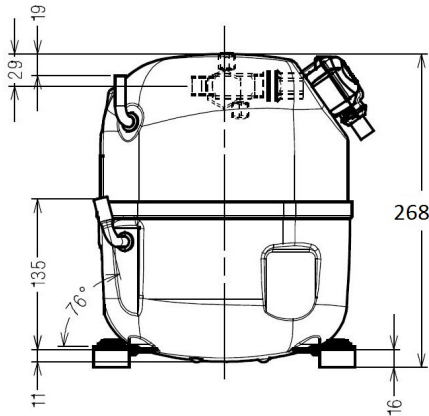

* EN12900 : T°Cond. 40.0°C / T°Evap. -35.0°C / T°Return gas temp.. 20.0°C
T°Subcooling. 0.0K

Certificates :

Displacement (cc)	18.3
Net Weight (Kg)	20.1
Oil Quantity (cc)	475.0
Oil Type	Polyolester
Expansion Device	Capillary_Tube/Expansion_Valve
Cooling	Fan
Main Winding (Ohm)	4.5
Start Winding (Ohm)	9.8
Current	
RLA (A)	2.4
MCC (A)	5.9
LRA (A)	21
Electrical Equipment	CSR
Overload	MRA38111
Time Check	7.5s - 14s / 15.4 A
Open Temp	105° C
Close Temp	52° C
Optional	T0348
Start Capacitor	88 µF / 330 V
Run Capacitor	15 µF / 400 V
Potential Relay	RVA4P**
Pick Up	300/328V
Drop Out	60/121V
Optional	3ARR3*10AD*
Refrigerating connection for OD	
Suction Tube	12.7 (1/2")
Discharge Tube	7.9 (5/16")
Process Tube	6.35 (1/4")

Note : Tecumseh reserves the right to change information contained in this document without notification.



Tecumseh

CAJ2432X	Tension FZ : 220 - 240V 1~ 50 Hz
-----------------	---

Les performances sont données dans les **conditions EN12900** :
 Condition Dew
 The performance data are in **EN12900 conditions** :
 Dew Condition

Gaz aspirés : 20.0 °C
 Sous refroidissement : 0.0 K
 Return gas : 20.0 °C
 Subcooling : 0.0 K

© 2018 Tecumseh Products Company
All rights reserved

50 Hz R452A

N°2333

4 T condensation	5 T évaporation	(°C)	-40	-35	-30	-25	-20	-15	-10
30	1 P frigorifique	(Watt)	312	457	637	858	1124	1441	1812
	2 P absorbée	(W)	336	390	444	500	560	623	693
	3 I absorbée	(A)	1.52	1.74	1.98	2.24	2.53	2.83	3.16
40	1 P frigorifique	(Watt)	226	350	505	695	925	1200	1524
	2 P absorbée	(W)	319	384	452	522	596	675	760
	3 I absorbée	(A)	1.45	1.73	2.02	2.34	2.67	3.03	3.40
50	1 P frigorifique	(Watt)		245	371	527	718	948	1223
	2 P absorbée	(W)		361	440	523	611	704	804
	3 I absorbée	(A)		1.64	1.99	2.36	2.74	3.14	3.57
60	1 P frigorifique	(Watt)				364	513	696	917
	2 P absorbée	(W)				505	605	711	825
	3 I absorbée	(A)				2.30	2.74	3.19	3.65

50 Hz R404A

N°2292

4 T condensation	5 T évaporation	(°C)	-40	-35	-30	-25	-20	-15	-10
30	1 P frigorifique	(Watt)	352	506	697	927	1202	1524	1897
	2 P absorbée	(W)	340	398	456	516	577	641	709
	3 I absorbée	(A)	1.63	1.87	2.13	2.40	2.69	3.00	3.32
40	1 P frigorifique	(Watt)	259	391	552	748	981	1257	1577
	2 P absorbée	(W)	327	397	467	540	616	696	781
	3 I absorbée	(A)	1.58	1.87	2.18	2.51	2.85	3.21	3.58
50	1 P frigorifique	(Watt)		276	408	567	759	986	1253
	2 P absorbée	(W)		376	458	543	633	728	830
	3 I absorbée	(A)		1.80	2.16	2.54	2.93	3.34	3.77
60	1 P frigorifique	(Watt)			269	392	540	718	929
	2 P absorbée	(W)			430	528	631	740	857
	3 I absorbée	(A)			2.07	2.50	2.94	3.40	3.88

1 = cooling capacity 2 = power input 3 = current 4 = condensing temperature 5 = evaporating temperature

Nota : Tecumseh se réserve le droit de modifier les informations contenues dans ce document sans préavis.

Note : Tecumseh reserves the right to change information contained in this document without notification.



Tecumseh

CAJ2432X	Tension FZ : 220 - 240V 1~ 50 Hz
-----------------	---

Les performances sont données dans les conditions EN12900 :	Gaz aspirés :	20.0 °C
Condition Dew	Sous refroidissement :	0.0 K
The performance data are in EN12900 conditions :	Return gas :	20.0 °C
Dew Condition	Subcooling :	0.0 K

50 Hz R449A (*)

N°2606

4 T condensation	5 T évaporation	(°C)	-40	-35	-30	-25	-20	-15	-10
30	1 P frigorifique	(Watt)	249	387	562	781	1048	1367	1743
	2 P absorbée	(W)	307	361	416	471	529	591	657
	3 I absorbée	(A)	1.39	1.62	1.86	2.11	2.39	2.68	3.00
40	1 P frigorifique	(Watt)	180	296	446	633	864	1142	1473
	2 P absorbée	(W)	296	361	427	495	565	640	719
	3 I absorbée	(A)	1.35	1.62	1.91	2.22	2.53	2.87	3.22
50	1 P frigorifique	(Watt)		209	333	490	685	922	1207
	2 P absorbée	(W)		342	420	500	583	671	764
	3 I absorbée	(A)		1.56	1.90	2.25	2.62	3.00	3.39
60	1 P frigorifique	(Watt)				358	517	715	954
	2 P absorbée	(W)				486	582	684	792
	3 I absorbée	(A)				2.21	2.63	3.06	3.50

© 2018 Tecumseh Products Company
All rights reserved

1 = cooling capacity 2 = power input 3 = current 4 = condensing temperature 5 = evaporating temperature

(*) Veuillez vous référer strictement aux Recommandations d'Utilisation et Bulletins Marketing Tecumseh du fait de la température de refoulement élevée pour les applications LBP.

(*) Due to very high discharge temperature especially on LBP conditions, please strictly refer to Tecumseh Guidelines & Marketing Bulletin when using this refrigerant.

Nota : Tecumseh se réserve le droit de modifier les informations contenues dans ce document sans préavis.

Note : Tecumseh reserves the right to change information contained in this document without notification.